



Gemini 2 L

Datasheet v1.1

Product Brief	02
Product Specifications	02
Product Information	04
SDK	04
Camera Setup and Operation	05
Installation Guide	05
Product Drawings	06
Multi-Camera Synchronization	06
Safety and Handling	07
Principles of Depth Field of View	07
Glossary of Terms	08



1. Product Brief

Product Overview

The Orbbec Gemini 2 L is based on active stereo IR technology with a baseline of 100mm and is equipped with Orbbec’s latest custom ASIC for high quality depth processing. It has a depth Field of View (FoV) of up to 101° diagonally and operates with a single USB 3.0 cable for power and connectivity. The camera also has a proximity sensor for close distance single point ranging, which eliminates any blind spot in depth measurements within the entire 0–10m range. An internal IMU enables motion and position tracking.

Gemini 2 L is easy to set up and operate with the Orbbec SDK, and the camera delivers extremely accurate and reliable data in various lighting conditions from pitch black to semi-outdoor.

Product Features:

- Global shutter for RGB and IR cameras
- Wide Field of View at 91° Horizontal and 66° Vertical
- High quality depth data output from 0.25m to 10m
- Up to 60fps at 640x400 and 30fps at 1280x800 depth resolutions
- USB Type-C for power and data connectivity
- Internal IMU
- Multi-camera synchronization

2. Product Specifications

Parameter	Specifications
Model	G20055-I5
VID/PID	0x2BC5/0x0673
Technology	Active Stereo IR
Shutter Type	IR: Global Shutter; Color: Global Shutter
Wavelength	850nm

Product Specifications (continued from previous page):

Mode	Resolution	FoV	FPS	Range	Format
Unbinned Dense Default	1280 x 800	H 91° x V 66°	5, 10, 15, 30	0.25m - 10m (Optimal Range) 0.30m - 7.0m	Y16Y14/ RLE
	640 x 400		5, 10, 15, 30		
	320 x 200		5, 10, 15, 30		
Unbinned Sparse Default	1280 x 800		5, 10, 15, 30	0.25m - 10m (Optimal Range) 0.30m - 7.0m	
	640 x 400		5, 10, 15, 30		
	320 x 200		5, 10, 15, 30		
Binned Sparse Default	640 x 400	5, 10, 15, 30, 60	(Optimal Range) 0.25m - 5.0m		
	320 x 200	5, 10, 15, 30, 60			
Dimensioning	1280 x 800	5, 10, 15, 30	(Optimal Range) 0.30m - 4.0m		
	640 x 400	5, 10, 15, 30			
	320 x 200	5, 10, 15, 30			
RGB	1280 x 800	H 94° V 68°	5, 10, 15, 30, 60	YUYV/ MJPEG	
	1280 x 720		5, 10, 15, 30, 60		
	800 x 600		5, 10, 15, 30, 60		
	640 x 400		5, 10, 15, 30, 60		
	640 x 360		5, 10, 15, 30, 60		
Depth Accuracy: ≤ 2% (1280 x 800 @ 2m & 81% ROI). The test object has a reflectivity > 80% plane, and the reference range is 81% FoV (81% FoV is the remaining center 81% of the depth map area after cropping 5% of the top and bottom of the depth map). The root mean square of the distance sequence from all valid points in the area to the best-fit point of the fitted plane is calculated. Measured object reflectivity > 10%, up to 10m distance depth data, but the actual accuracy varies with the distance and the object to be measured.					

Parameter	Specifications
Baseline	100mm
IMU	6 DoF; Frequency range: 50-2,000Hz. Data format: float
Mirror Mode	Supported, non-mirror by default
Processing	Internal processing using Orbbec MX6600 ASIC
Data Connection	USB 3.0 & USB 2.0 USB Type-C for data and power
Operating Modes	Unbinned Dense Default: High accuracy and High-density depth data. Unbinned Sparse Default: Balanced depth accuracy and power consumption. Binned Sparse Default: Low power mode, supports 60fps, small blind zone. Dimensioning: High quality depth data.
Power Consumption	Average < 3W (Peak 10.0W)
Operating Environment	0° - 40°, 8%RH - 90 %RH (non-condensing), Indoor/Semi-Outdoor
Anti-flicker	50Hz & 60Hz
Supported Functions	D2C, Multi-Camera Sync
Dimensions WxHxD	124mm x 29mm x 26mm
Weight	152g
Certifications	Class 1, RoHS, FCC, CE, Reach, KC
Installation	1 x ¼-20 UNC 2 x M3

3. Product Information

3.1 Product Images

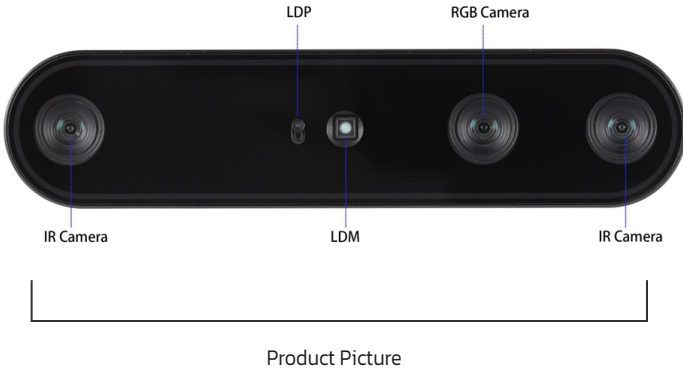

3.2 Product Interfaces

The hardware interfaces of Gemini 2 L camera are shown in the figure below.

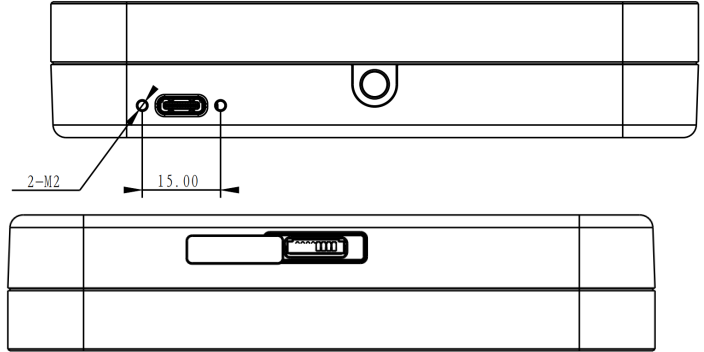

Data Transmission	Synchronization
USB Type-C	8-Pin

4. Software Development Kit (SDK)

Orbbec SDK is a flexible and modular platform for easy camera setup and runs on Linux/Windows with a rich set of APIs. It supports camera access, device setup and configuration, data stream reading, processing, viewing, RGB-D registration and frame synchronization.

Included functions:

- Access and control of camera devices.
- Control of frame synchronization and alignment.
- Acquisition of point cloud data.
- Orbbec Viewer for camera testing.

Please check <https://www.orbbec.com/developers/orbbec-sdk/> for the latest SDK.

Temperature sensor and recording

The temperature of camera core components – including laser temperature, IR sensor temperature and IMU sensor temperature – can be obtained through API commands.

5. Camera Setup and Operation

Packing List

Package Type	Camera	USB Cable	Tripod
Box			
Bulk		N/A	N/A

Initialization and Operation

- Connect Gemini 2 L to the host PC via the USB cable.
- Download Orbbec SDK from <https://www.orbbec.com/developers/orbbec-sdk/>
- Use Orbbec Viewer to validate that images can be streamed from all sensors with the following settings:
 - Depth camera: Unbinned Dense Default, 1280x800
 - RGB camera: 1280x800
 - IMU enabled
- If the camera is not responding or not being detected for some reason, please unplug all cables from the camera and replug to the host PC to reset the camera state.

6. Installation Guide

Use outside of the specified conditions could cause the device to fail and/or function incorrectly. These conditions are applicable for the environment immediately around the device under all operational conditions. When used with an external enclosure, active temperature control and/or other cooling solutions are recommended to ensure the device is maintained within these ranges.

6.1 Installation Recommendations

1. When using external housing around the camera for dust proofing, use foam inserts or rubber gaskets between the front of the camera and the external housing.
2. Avoid the application of external forces to the camera chassis during the installation process.
3. Disassembling chassis and mounting brackets will void the warranty.

6.2 Heat Dissipation

1. Avoid any direct heat sources around the camera.
2. Maximizing the space inside the external housing may help lower operating temperature.

6.3 Transmittance Requirements

The current light transmission of the Gemini 2 L front cover glass lens is as follows:

1. RGB (420~650nm) transmittance rate $\geq 91\%$
2. IR, LDM (858 ± 20 nm) transmittance rate $\geq 91\%$
3. LDP (940nm ± 30) transmittance rate $\geq 91\%$

Before changing the structural design of the camera, the protective lens in front of the camera lens must meet the requirements above.

6.4 Cable Design Guide

It is recommended to use the included USB Type-C cable. If a longer cable is needed, please select a USB certified cable that supports both power and data (1-1.5m length is recommended).

7. Product Drawings

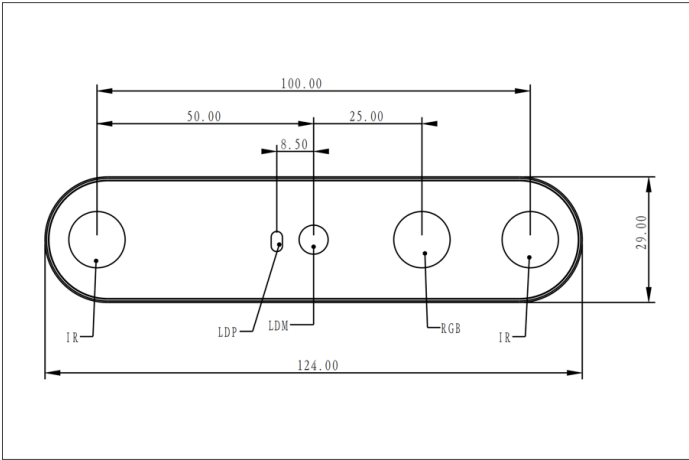

Front View

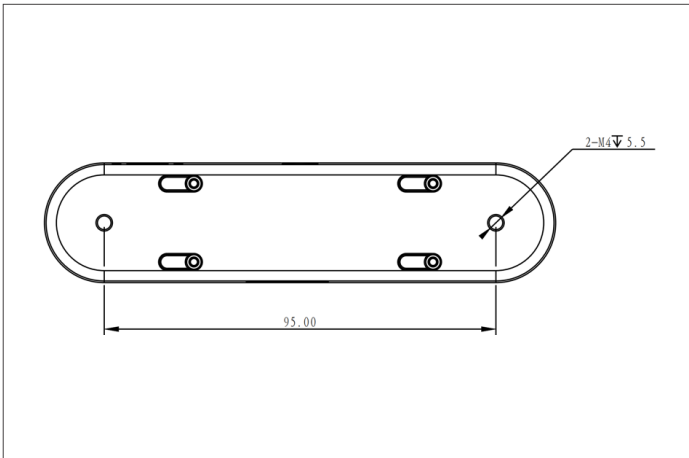

Bottom View

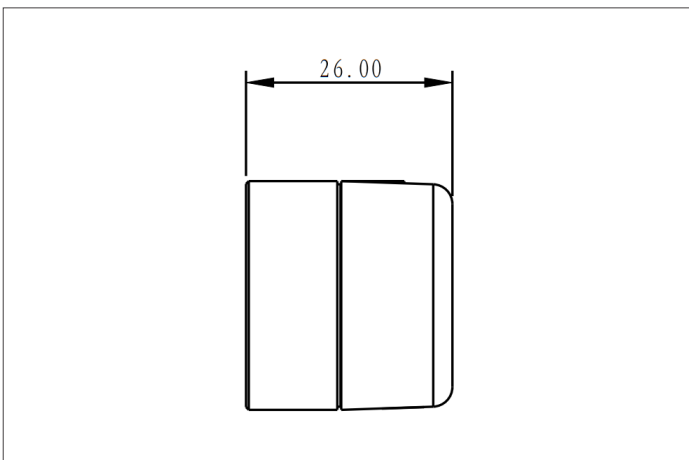

Side View

8. Multi-Camera Synchronization

Advantages of multi-camera setup

- Increase camera coverage in a given space and fill in the occlusions where a single camera may have blind spots.
- Capture multiple images of the same scene and scan objects from different angles.
- Increase the effective frame rate to greater than 30 frames per second (FPS).

Using an 8-pin connector and matching cable, a multi-camera and multi-sensor network can be designed. (Please follow the instructions in the SDK).

Multi-camera and multi-sensor synchronization in different configurations can be designed with the optional Orbbec's Multi-Camera Sync Hub Dev and Multi-Camera Sync Hub Pro accessories.

Synchronization Interfaces of Gemini 2 L Camera

Pin	Definitions	Description
Pin_1	VCC	The default is 1.8V. When 3.3V or 5V drive voltage is provided on the VCC interface, the I/O level setting can be adjusted to 3.3V or 5V as required
Pin_2	GPIO_OUT	Synchronization drive signal: Active high. The high-level interval coincides with the IR exposure time. Typical application is to drive external fill light.
Pin_3	VSYNC_OUT	Synchronous trigger signal: Active high. The high level provides the triggering signal for the secondary devices.
Pin_4	TIMER_SYNC_OUT	Pulse signal source, reset hardware timestamp of secondary devices.
Pin_5	RESET_IN	Hardware reset signal: Triggers the camera to power down and automatically power up and reset. Detect the input signal: 20Hz / 50% duty cycle / more than 5 consecutive cycles, that is, judged as normal input signal, other signals filtered out; allowed fluctuations for frequency ± 1 Hz, duty cycle $\pm 2\%$.
Pin_6	VSYNC_IN	Synchronous trigger signal: Active high. Generated for the triggering/sync signal by the primary device, with a duration of 1ms.
Pin_7	TIMER_SYNC_IN	Hardware timestamp reset signal input, hardware timestamp clearing
Pin_8	GND	Ground

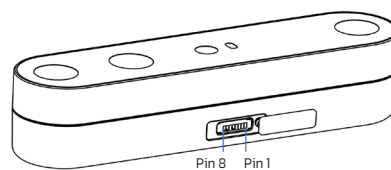

*The Pin sequence is shown with the rear view of the camera

9. Safety and Handling

1. Follow the camera operation instructions Improper operation may cause damage to internal components.
2. Do not drop or subject the camera to external force.
3. Do not attempt to modify the camera as modifications may cause permanent damage or inaccuracies.
4. The camera temperature may increase during long periods of continuous usage.
5. Do not touch the lens. Fingerprints on the lens may affect image quality.
6. Keep the product beyond the reach of children or animals to avoid accidents.
7. If the camera is not recognized by the computer, check if the cable meets the power/data transfer requirements and reinsert the USB for reconnection.
8. This product uses a Class 1 laser. Looking at the laser for more than 20s is not recommended.

10. Principles of Depth Field of View

The image below shows the depth camera field-of-view, or the angles that the sensors "see". This diagram shows the IR camera.

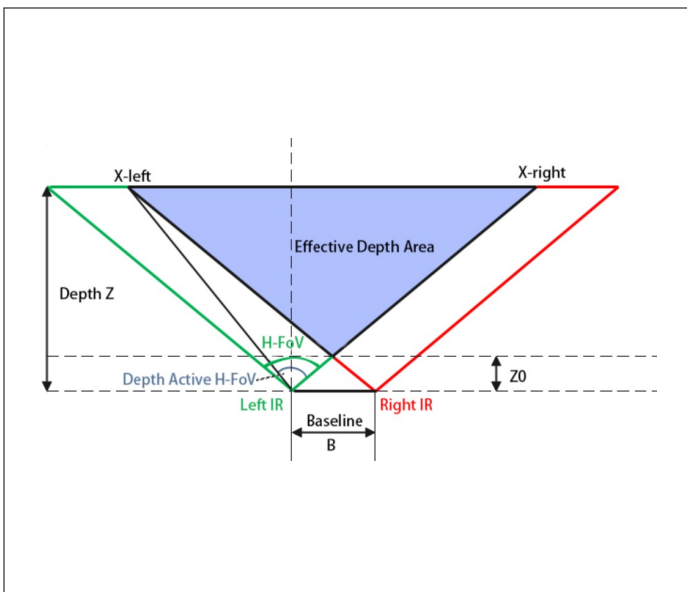

Depth Field of View (Depth FOV) at any distance (Z) can be calculated using the following equation:

$$\text{Depth Active H - FoV} = \arctan\left(\frac{cx}{fx} - \frac{B}{Z}\right) + \arctan\frac{\text{width} - 1 - cx}{fx}$$

$$H - FoV = \arctan\frac{cx}{fx} + \arctan\frac{\text{width} - 1 - cx}{fx}$$

$$Z0 = \frac{B}{2\left(\tan\frac{H-FoV}{2}\right)}$$

Definitions:

1. cx = X-direction image coordinates of the main point of the depth image
2. fx = Depth camera focal length
3. width = Depth image width
4. $H\text{-FoV}$ = IR $H\text{-FoV}$

Note: cx , fx , and width parameters are obtained through the SDK Depth Intrinsic for the relevant camera parameters, and each 3D camera parameter is not the same.

11. Glossary of Terms

Term	Definition
D2C	Depth to Color function maps each pixel on a depth map to the corresponding color image according to the intrinsic and extrinsic parameters of depth camera and color camera.
Depth	Depth video streams are like color video streams except each pixel has a value representing the distance away from the sensor instead of color information.
Depth Camera	Includes the external interface and the depth imaging module, which is generally composed of the infrared projector, the infrared camera, and the depth computing processor.
FOV	Field of View (FoV) describes the angular extent of a given scene that is captured by a camera, which can be measured in horizontal, vertical, or diagonal.
I2C	I2C bus refers to a kind of simple bidirectional two-wire synchronous serial bus developed by Philips. It can be used for transferring information among devices connected to the bus with two wires.
IR Camera	Infrared camera.
IR Flood	IR floodlights are used to illuminate the environment.
ISP	Image Signal Processor, which is used for image post-processing.
MIPI	Mobile Industry Processor Interface (MIPI) is an open standard and specification formulated by the MIPI Alliance for mobile application processors.
PCBA	Circuit board that includes the depth computing processor, memory, and other electronic devices.
Point Cloud	A point cloud is a discrete set of data points in space.
SoC	System on Chip, an integrated circuit (IC) that integrates all components of a computing system.
TBD	To Be Determined. In the context of this document, information will be available in a later revision.

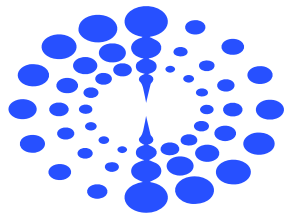

ORBBEC